

KFM 110 / 220 / 440 Mixers

UltraSource's heavy duty, all stainless steel mixers feature automatic forward and reverse mixing action that results in the most thorough mixtures for a full range of products. Choose from three models: 110-lb., 220-lb., or 440-lb. capacity.

Each machine features a single mixing arm with paddle that gently lift and mix product. The stainless steel lid has viewing slots so spices or other ingredients can be easily added during the mixing process. When a batch is complete, the hopper tilts at 95° for easy unloading and cleaning.

Safety switches are located next to the machine's lid. For added safety, mixing action stops when lid is slightly raised.

The KFM-440 is the largest model and is designed for high capacity production environments. It comes equipped with an optional hopper lift system to automate production and minimize lifting related injuries and Workers' Compensation claims. KFM-110 and KFM-220 models are available with optional stands to elevate the working height and provide a 28" clearance below the tilted tank. (See reverse panel)

UltraSource's heavy duty mixers are used to produce a full range of high quality products including:



KFM-220
220-lbs. Capacity
Mixer

KFM-110
110-lbs. Capacity
Mixer



KFM-440 shown
with optional lift

Ground meat or poultry	Meat loaves	Sausage	Fish products
Dough and other bakery fillings Hopper Volume	Salad Mixes	Vegetables	Dressings
Pasta fillings	Dry food stuffs	Wild game	Non food products

KFM 110 / 220 / 440 Mixers

KFM Stainless Steel Mixer Specifications

Specifications		KFM 110	KFM 220	KFM 440
Hopper Capacity		110-lbs.	220-lbs.	440-lbs.
Hopper Width	A	23" (584 mm)	26" (660 mm)	38.5" (980 mm)
Hopper Height	B	16.5" (419 mm)	21" (533 mm)	24" (609 mm)
Machine Width	C	32.25" (819 mm)	37.5" (953 mm)	56.5" (1,435 mm)
Machine Depth	D	15.25" (387 mm)	22.5" (572 mm)	31.5" (800 mm)
Machine Height	E	43" (1,092 mm)	43" (1,092 mm)	59.4" (1,510 mm)
Mixing Arm Speed		Up to 36 RPM	Up to 39 RPM	Up to 44 RPM
Motor Horsepower		1-hp	2-hp	3-hp
Electrical		220 volt, 60Hz, single-phase	220 volt, 60Hz, 3-phase	230 or 400 volt, 60Hz, 3-phase
Net Weight		344-lbs. (156 kg)	408-lbs. (185 kg)	849-lbs. (385 kg)

KFM 440

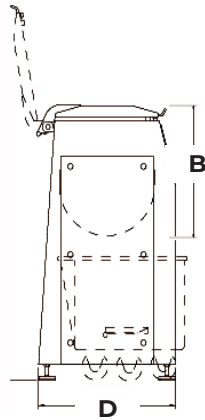
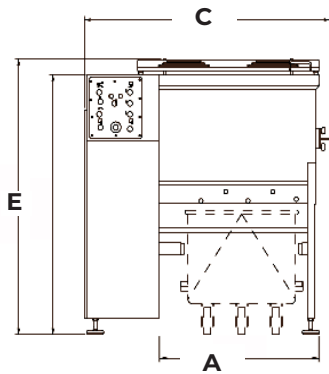

KFM 110 and KFM 220

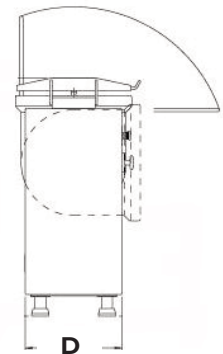
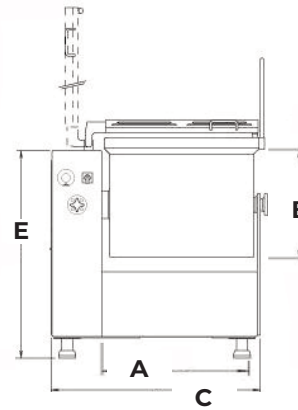

Optional Lift Kits

Provide up to 28" clearance below tilted tank



Mixer Lift Kit
Option for KFM 110



Mixer Lift Kit
Option for KFM 220