

# ULTRAVAC® 225

## VACUUM PACKAGING MACHINE

### The UltraSource space saving Ultravac® 225

In less than 3.25 square feet (19" x 24.6") of counter space you can begin vacuum packaging a wide range of small to large size products. Vacuum chamber size: 7.25" deep x 16.75" x 19.56" long.

- Quick change, 16" seal bar.
- Our Pozi Pressure® radius surface sealing element seals through contaminants, folds, and wrinkles.
- Compact tabletop model saves valuable counter space.
- Simple operation and easy to use controls.
- Ideal for small processors, restaurants, and supermarkets.
- Patented lid hinge system minimizes stress on lid to eliminate cracking.

### Optional Features:

- Gas flush
- Single seal with cut off
- Digital control panel



### Contact us at:

UltraSource LLC  
1414 West 29th Street  
Kansas City, MO 64108-3604 USA

**800.777.5624**

P: 816.753.2150

F: 816.753.4976

info@UltraSourceUSA.com

UltraSourceUSA.com



## UltraSource®

© Copyright 2013 UltraSource LLC

**Think UltraSource First.**

# ULTRAVAC<sup>®</sup> 225



## VACUUM PACKAGING MACHINE

### Injection molded from high tech, engineered composite.

Space age, engineered resin composite materials in the Ultravac 225's chamber lid, basin, and chassis are amazingly flexible yet virtually indestructible. This composite was developed with input from a Technology Transfer Program between UltraSource and the U.S. Department of Energy. Both lid and basin are smooth and seamless with large radius corners for easy, thorough cleaning and inspection.

### Quick change, 16" seal bar.

Features UltraSource's Pozi Pressure<sup>®</sup> radius surface sealing element for sealing through contaminants, folds, and wrinkles.

### Large capacity chamber.

The Ultravac 225 vacuum chamber size: 7.25" high x 16.75" wide x 19.56" long.

### Standard Features:

- Rugged 1.25-hp vacuum pump
- High density polyethylene filler boards
- NEMA 4 washdown controls
- Patented lid hinge system minimizes stress on lid to eliminate cracking

### Ultravac 225 Single Chamber Vacuum Packaging Machine

Specifications	
A Length	19.25"
B Width	25"
C Maximum Height	32.25"
D Working Height	14.375"
Seal Bar Length	16"
E Chamber Length	19.56"
F Chamber Width	16.75"
G Chamber Height	7.25"
H Between Seal Bar and Back of Chamber	17.25"
Vacuum Pump	0.95kW (1.25-hp)
Net Weight	121 lbs.
Electrical Connection	110V, 60Hz (single phase), 15 amps 230V, 50/60Hz (single phase), 6.5 amps

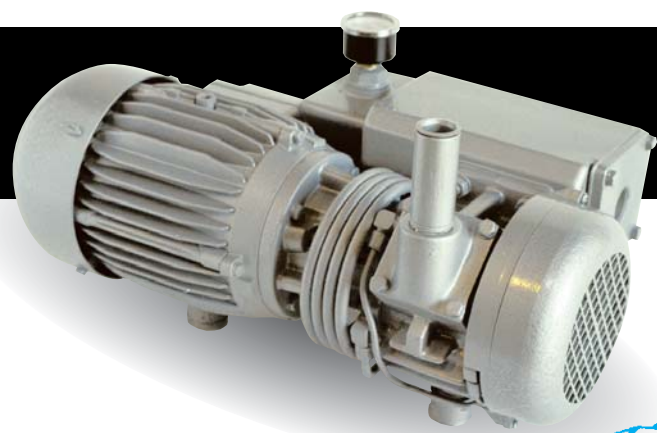

The heavy duty, 1.25-hp vacuum pump powers the Ultravac 225 for years of dependable service

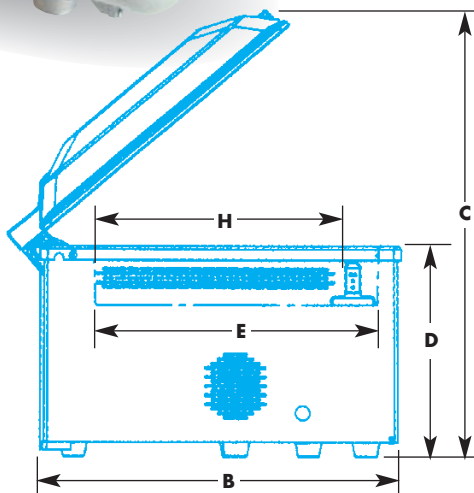
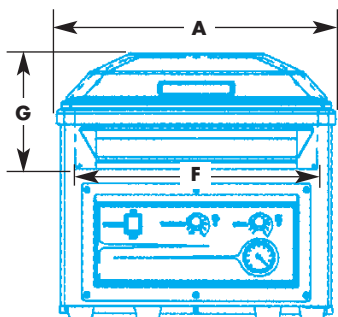

ETL Listed, conforms to:  
UL-73, CSA-C22.2 No. 68-92, NSF-2



Certified



UltraSource<sup>®</sup>